



60W Triple output power supply

HS Series

- High efficiency, long service life and high reliability
- output protection function: Over current/short circuit
- ultra wide operating temperature range -30°C~70°C
- long service life electrolytic capacitor
- 100% full load ageing test
- no fan, quiet
- 3 years



MODEL	HS-60T-B			HS-60T-C			HS-60T-D			
OUTPUT	DC Output	5V	12V	-12V	5V	15V	-15V	5V	12V	24V
	Rated Current	5A	2A	1A	5A	1.5A	1A	3A	2A	1A
	Current Range	0.5~5A	0~2A	0~1A	0.5~5A	0~1.5A	0~1A	0.5~3A	0~2A	0~1A
	Ripple and Noise	50mV	120mV	120mV	50mV	200mV	200mV	200mV	120mV	200mV
	Voltage ADJ. Range	±10% of rated output voltage								
	Voltage Accuracy	±2.0%	±8.0%	±3.0%	±2.0%	±8.0%	±3.0%	±8.0%	±6.0%	±8.0%
	Line Regulation	±0.5%	±1.5%	±1.5%	±0.5%	±1.5%	±1.5%	±0.5%	±2%	±2%
	Load Regulation	±1%	±3%	±3%	±1%	±3%	±3%	±1%	±3%	±4%
	Set-up Time	< 1S (230VAC input), < 2S (115VAC input)								
	Hold up Time	< 70ms/230VAC 15ms/115VAC								
INPUT	Voltage Range	88Vac~264Vac								
	Frequency Range	47Hz~63Hz								
	Efficiency	73%			73%			73%		
	Inrush Current (Typical)	< 30A@230VAC < 20A@115VAC Cold start								
PROTECTION	Over Load	105%~135% of rated output current, hiccup mode, auto recovery								
	Over power	120%~130% of rated output current, hiccup mode, auto recovery								
	Short Circuit	Long-term mode, auto recovery								
ENVIRONMENT	Operating amb. Temp. & Hum.	-30°C~70°C; 25%~90%RH								
	Storage Temp. & Hum.	-40°C~85°C; 10%~95%RH								
SAFETY&EMC	Safety Standards	Reference GB4943/EN60950, UL62368-1, TUV EN62368-1								
	Withstand Voltage	Primary-Secondary:3.0KVac; Primary-PG:1.5KVac; Secondary-PG:0.5KVDC								
OTHERS	MTBF (MIL-HDBK-217F)	More than 100,000Hrs (25°C, Full load)								
	Dimension (L*W*H)	159*98*38mm								
	Packing	400g/PCS								
	Cooling method	Cooling by free air convection								
NOTE	1. All parameters NOT specially mentioned are measured at rated input, rated load and 25°C of ambient temperature.									

Block diagram of internal mechanism

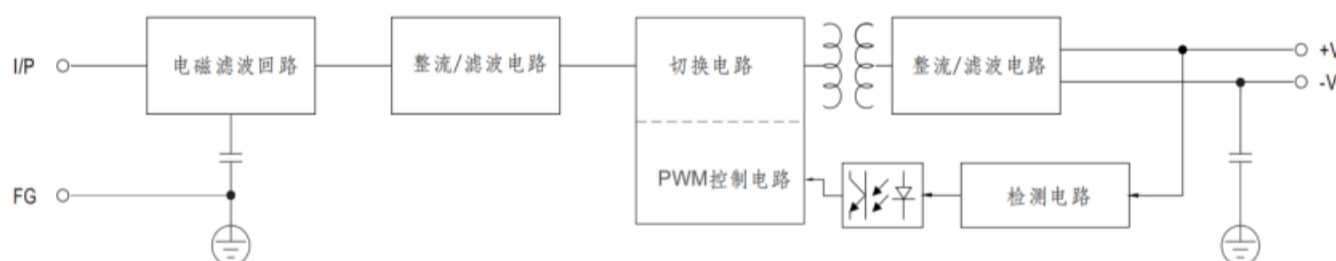

Organization size chart:

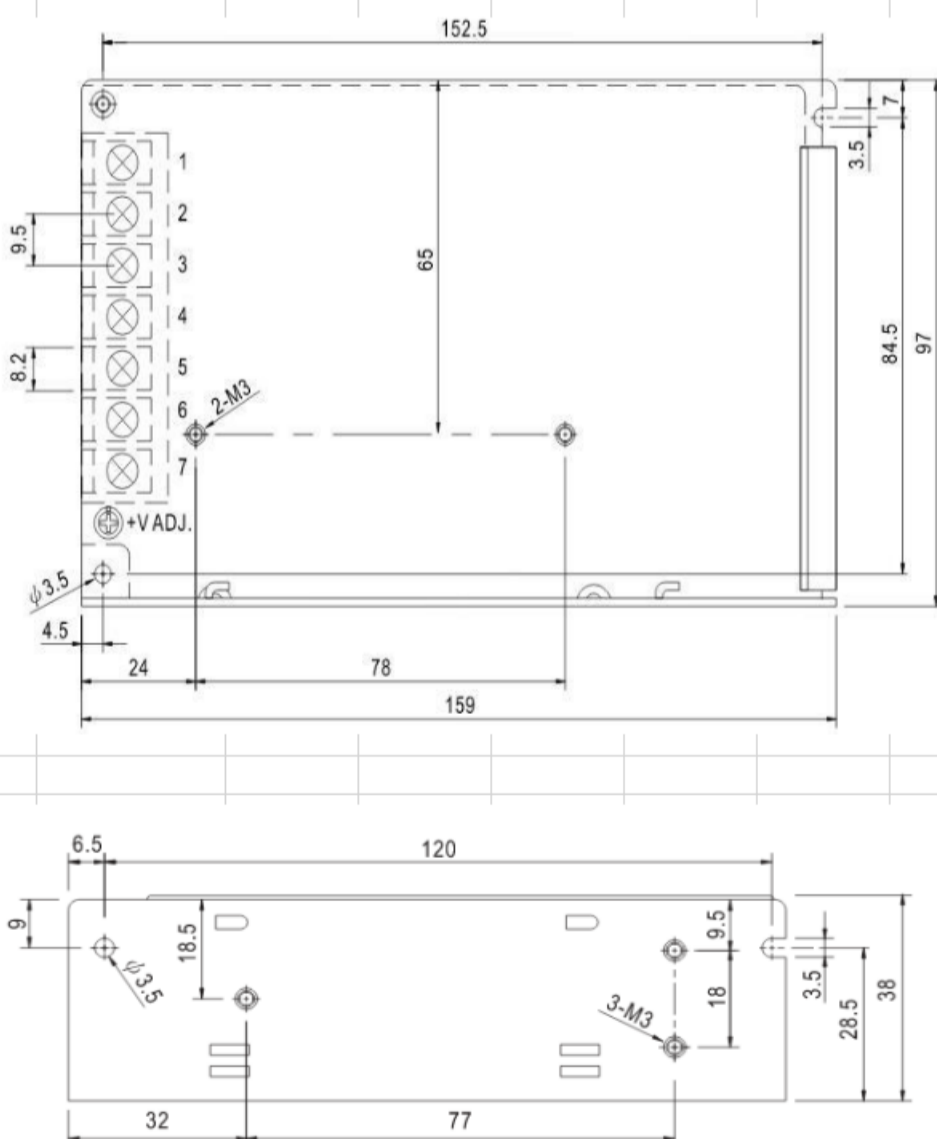

降额曲线:

